

APPLICATIONS: For use in wood pedestals, dresser, and desk drawers, casework, residential and kitchen cabinetry. **Heavy Duty Touch Release provides higher capacity for stay-closed feature.** Not intended for lateral file* drawer applications. Use for side mount only. This product is covered by U.S. and various foreign patents issued and/or pending.

Touch Release and Heavy-Duty Touch Release
Stays closed, push to open
Vertical Drawer Adjustment
Optional Face Frame Brackets

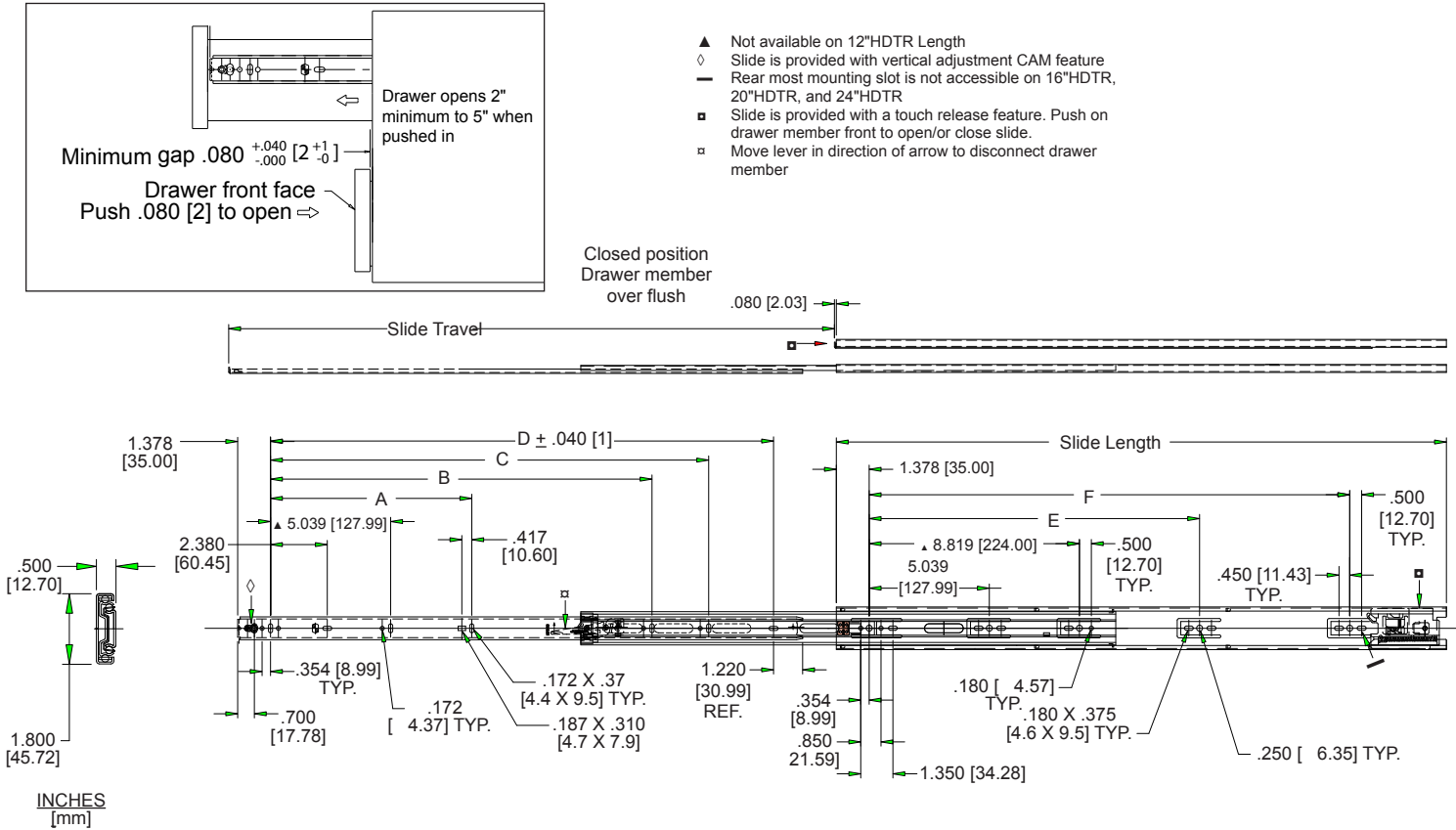

Finish	Clear electroplate (C), black electroplate (CB), or white electrocoat (EW) finish
Load Rating	100 lbs. [45.5 kg] per pair ♦
Length	12"–28" [300 mm–700 mm]
Hardware	Flat head 6 mm Euro System screw or #8 pan head screw
Side Space	.50" (+ .031-0.00) [12.7 mm] (+ 0.8-0.0)
Travel	Full extension
Height	1.80" [45.7 mm]
Disconnect	Handed lever disconnect
Mounting	Side, optional face frame brackets
Features	Drawer member vertical cam adjustment
Ball Bearings	C and CB finish: Steel EW Finish: Acetal polymer in drawer member

Part Number	Slide Length	3832TR Travel	A	B	C	D	E	F
3832-C12TR 3832-C12HDTR	11.81 [300]	12.00 [305]				7.58 [192]		
3832-C14TR 3832-C14HDTR	13.78 [350]	14.00 [356]				9.55 [242]		
3832-C16TR 3832-C16HDTR	15.75 [400]	16.00 [406]				11.51 [292]	11.34 [288]	
3832-C18TR 3832-C18HDTR	17.72 [450]	18.00 [457]		12.60 [320]		13.48 [342]	12.60 [320]	
3832-C20TR 3832-C20HDTR	19.69 [500]	20.00 [508]		12.60 [320]		15.45 [392]	15.12 [384]	
3832-C22TR 3832-C22HDTR	21.65 [550]	22.00 [559]	8.82 [224]	16.38 [416]		17.42 [442]	16.38 [416]	
3832-C24TR 3832-C24HDTR	23.62 [600]	24.00 [610]	8.82 [224]	16.38 [416]		19.39 [492]	13.86 [352]	18.90 [480]
3832-C26TR 3832-C26HDTR	25.59 [650]	26.00 [660]	8.82 [224]	16.38 [416]	20.16 [512]	21.36 [542]	13.86 [352]	20.16 [512]
3832-C28TR 3832-C28HDTR	27.56 [700]	28.00 [711]	8.82 [224]	16.38 [416]	20.16 [512]	23.33 [592]	13.86 [352]	21.42 [544]

NOTES:

- Drawer width should not exceed slide length.
- For optimal performance, make drawer 1-1/16" [27.0 mm] less than cabinet opening.
- Slides may not function properly if side space is less than .50" [12.7 mm].

* A lateral file drawer is wider than it is deep.
♦ Load rating based on 18" slides mounted in a 16" wide drawer cycled 50,000 times.

Installation Instructions

Install Cabinet Member

1. Separate slide members by simultaneously lifting up the left hand disconnect lever and pushing down the right hand lever.
2. Install cabinet (large) member first. For applications with an overlay drawer front, refer to Figure 1 for conventional mounting, and Figure 2 for 32 mm System Mounting.

Install Drawer Member

3. Install the drawer member with a screw through the cam adjuster and through a hole or slot at the rear.

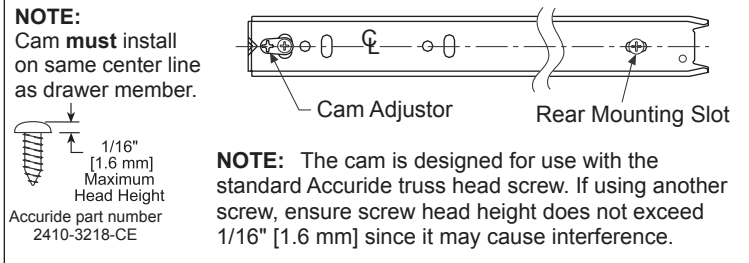

For cam adjustment, open drawer and rotate the cam with a Phillips or Pozi screwdriver to vertically position the drawer in relation to the cabinet.

NOTE:

Total vertical adjustment is 1/8" [3.2 mm] ±1/16" [1.6 mm] from center, up and down.

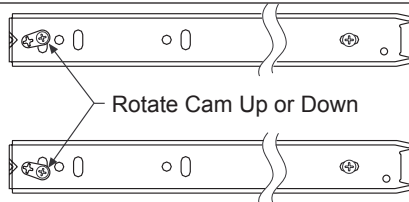

Install additional set screws to secure.

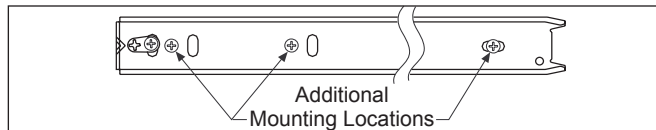

Overlay Mounting Instructions

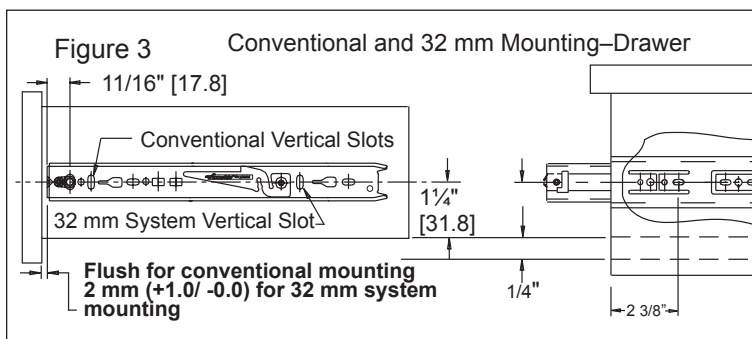
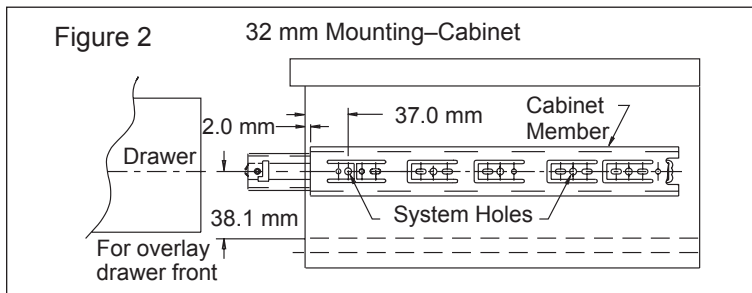
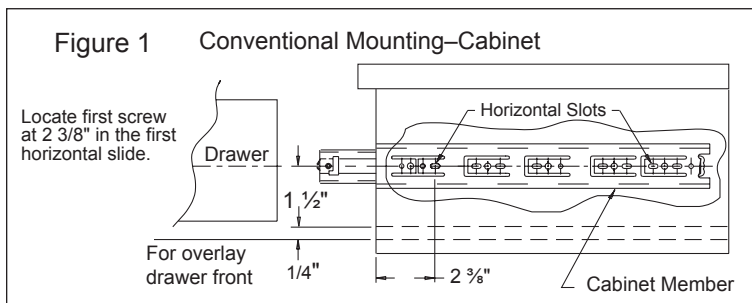

4. Make sure the ball bearing retainers in the cabinet side are fully forward. Install drawer into cabinet. Close the drawer.

Inset Mounting Instructions

1. Mount drawer member (Inner Member) flush to the back surface of the drawer front panel.
2. Mount cabinet member (Outer Member) 2 mm (.080) plus drawer front panel thickness inside (under flush) from front of cabinet.

Slide Ordering Instructions

Complete your slide order for Accuride models 3832CTR and 3832CHDTR by specifying the following:

50 pair C 3832 C18 HDTR P
50 Pair C 3832 C18 TR D*

Total Required Slides _____
Slide Finish _____
Slide Model _____
Slide Length _____
Push Close/Open _____
Polybag Packaging _____

*D-Pack only for 3832CTR

Optional Face Frame Brackets

Optional face frame brackets available. See Face Frame Conversion Kit technical sheet part number 4180-0661-XE for models 3832CTR and 3832CHDTR

Packaging

Distributor (D) Pack: All lengths are packaged 10 pair per box. Polybag includes one pair of slides with mounting screws (3832CTR only).

Bulk (P) Pack: All lengths are packaged 10 pair per box. Slides and screws are ordered and packaged separately (3832CTR and 3832CHDTR).

Specifications

Slide members and ball retainers: Cold rolled steel
Ball bearings: Carburized steel/acetel polymer

NOTE: Specifications, materials, prices, terms, and delivery are subject to change without notice.

Accuride

ACCURIDE INTERNATIONAL INC.

12311 Shoemaker Avenue
Santa Fe Springs, CA 90670

TEL (562) 903-0200
FAX (562) 903-0208
www.accuride.com

Manufacturing, Engineering, and Sales
United States • Germany • Japan • Mexico • United Kingdom • China

Copyright © 2007 Accuride International Inc. 3700-9503(1178)-R1-0707